

GRUNDORAM & GRUNDOCRACK

THE DRIVING FORCES



DYNAMIC RAMMING SYSTEMS
DYNAMIC PIPE BURSTING SYSTEMS



DYNAMIC DOUBLE PACK FOR STEEL PIPE INSTALLATION AND PIPE RENEWAL

GRUNDORAM

The pneumatically driven GRUNDORAM ramming machines provide thrust forces up to 40.000 Nm. Due to the galvanised one-piece machine housing and the elaborately tempered piston, the machine is especially robust, reliable and durable. The GRUNDORAM horizontal rammers can be operated in all kinds of soil with the exception of muddy areas, swamps and compact, non-displaceable soils.

The most common GRUNDORAM application is the horizontal installation of steel pipes up to ND 4000 mm with dynamic impact and a small displacement volume. Steel pipes are used as media pipes, for example within the domain of pipeline construction or as casing pipes for bundling supply and waste disposal lines but also for building subways, smaller culverts and pipe roofs for tunnel construction.

With the appropriate accessories, the GRUNDORAM horizontal rammers can also be used for vertical applications, to support HDD drilling (HDD Assist) and for dynamic pipe renewal.

DYNAMIC STEEL PIPE INSTALLATION

- Horizontal application
- Vertical application
- HDD Assist & Rescue

DYNAMIC PIPE BURSTING

DYNAMIC STEEL PIPE INSTALLATION

The dynamic steel pipe installation method with GRUNDORAM horizontal rammers enables the economic installation of casing or product pipes up to 4000 mm diameter over lengths up to 100 m in soil classes 1-5 (partly even class 6 - easily soluble rock).

Target precision is achieved because the dynamic impact punches through the ground, destroying obstacles so they need not be displaced in one piece and pushed forward. The soil is collected inside the open steel pipe which is usually emptied using compressed air and/or water. The particular advantage the TRACTO-TECHNIK rammers is that no press abutments are required, which significantly reduces set-up times.

GRUNDOCRACK

The GRUNDOCRACK machines are modified horizontal rammers that are equipped with a reverse gear. This allows the accessories to be dismantled quickly and ergonomically and the machines to be easily recovered even in confined spaces.

The GRUNDOCRACK machines are particularly suitable for the dynamic renewal of damaged pipes made of brittle materials in closed construction. In addition to pipe renewal, the GRUNDOCRACK can also be used for pipe rehabilitation and, with the appropriate accessories, for dynamic steel pipe ramming.

DYNAMIC PIPE RENEWAL

- Dynamic pipe bursting
- Dynamic calibre bursting
- Dynamic Tight-In-Pipe

DYNAMIC STEEL PIPE INSTALLATION

DYNAMIC PIPE RENEWAL

With the dynamic pipe bursting method, old pipes made of stoneware, asbestos and fibre cement, grey cast iron, plastic or plain concrete, are shattered and simultaneously replaced by new HD-PE pipes (long and short pipes) or PVC-U short pipes with equal or larger cross-section.

The pipe bursting method is used if the function of the old pipe is impaired: for example in case of misalignment, cracks, missing sole or partial collapse or if repair/renovation is no longer possible. The method is also suitable for pipelines that need more hydraulic capacity improved or when a new pipe with a new service-life is required.

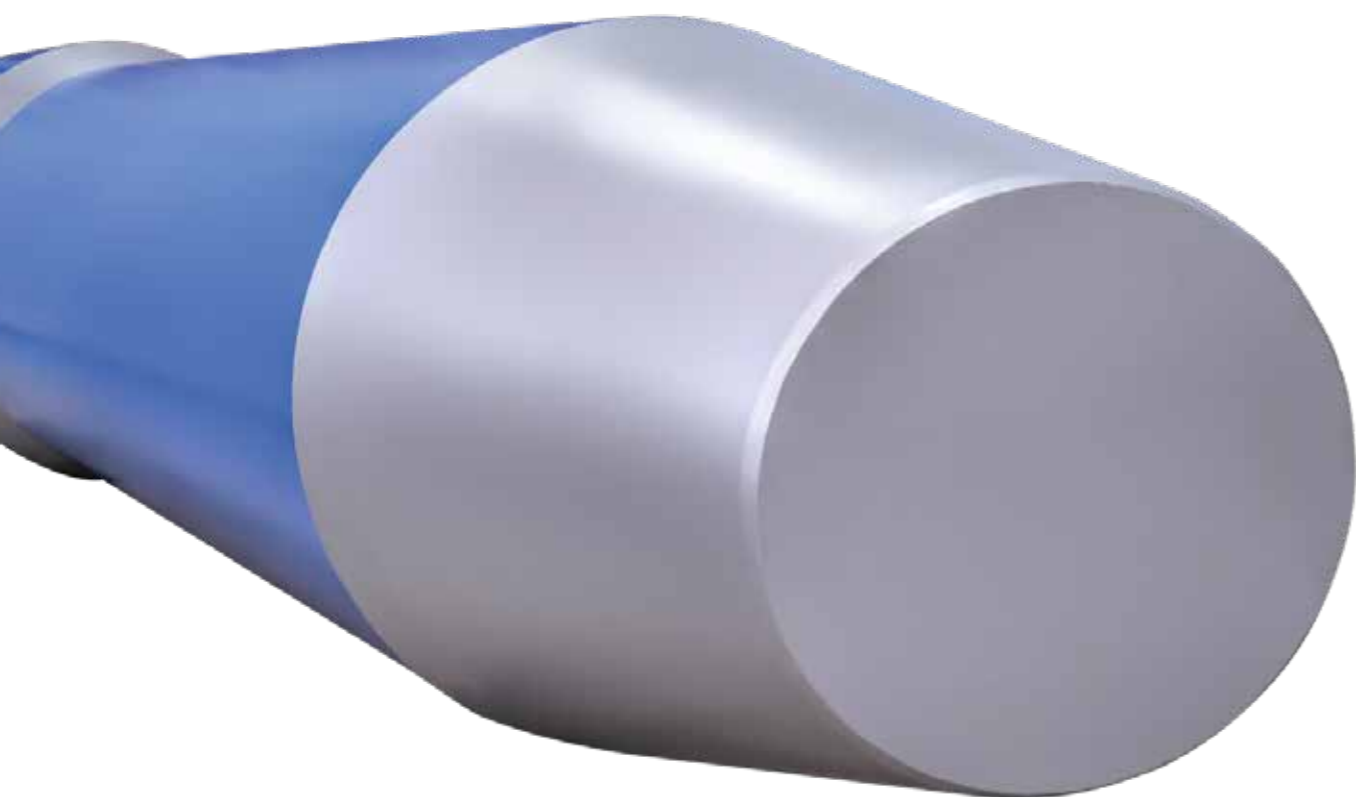

SMASHING GRUNDORAM

WITHOUT SCREWED CONNECTION



The TRACTO-TECHNIK pipe ramming units are the only ramming machines which can abandon threaded connections which are normally common practice. The connection hose is exchanged quickly, simply and problem-free without swaging.

FORGED FROM ONE PIECE



The massive housing consists of only one piece, manufactured from a single forged part and then galvanised. Due to precise deep hole boring, the piston impact makes its way to the head of the ramming machine, effectuating direct force transmission.

GRUNDORAM MINI MASCHINES

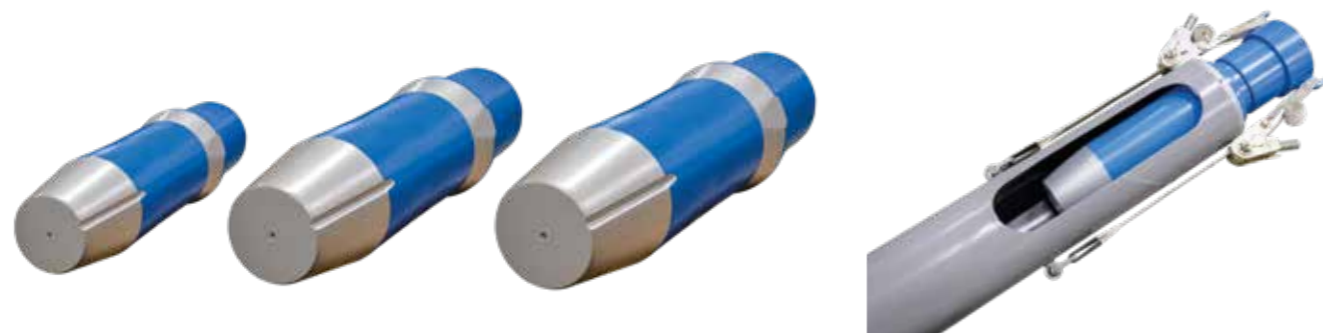

The short and highly efficient mini machines are ideal for propulsion in the pipe; they are the optimal choice for working in narrow and inaccessible places.

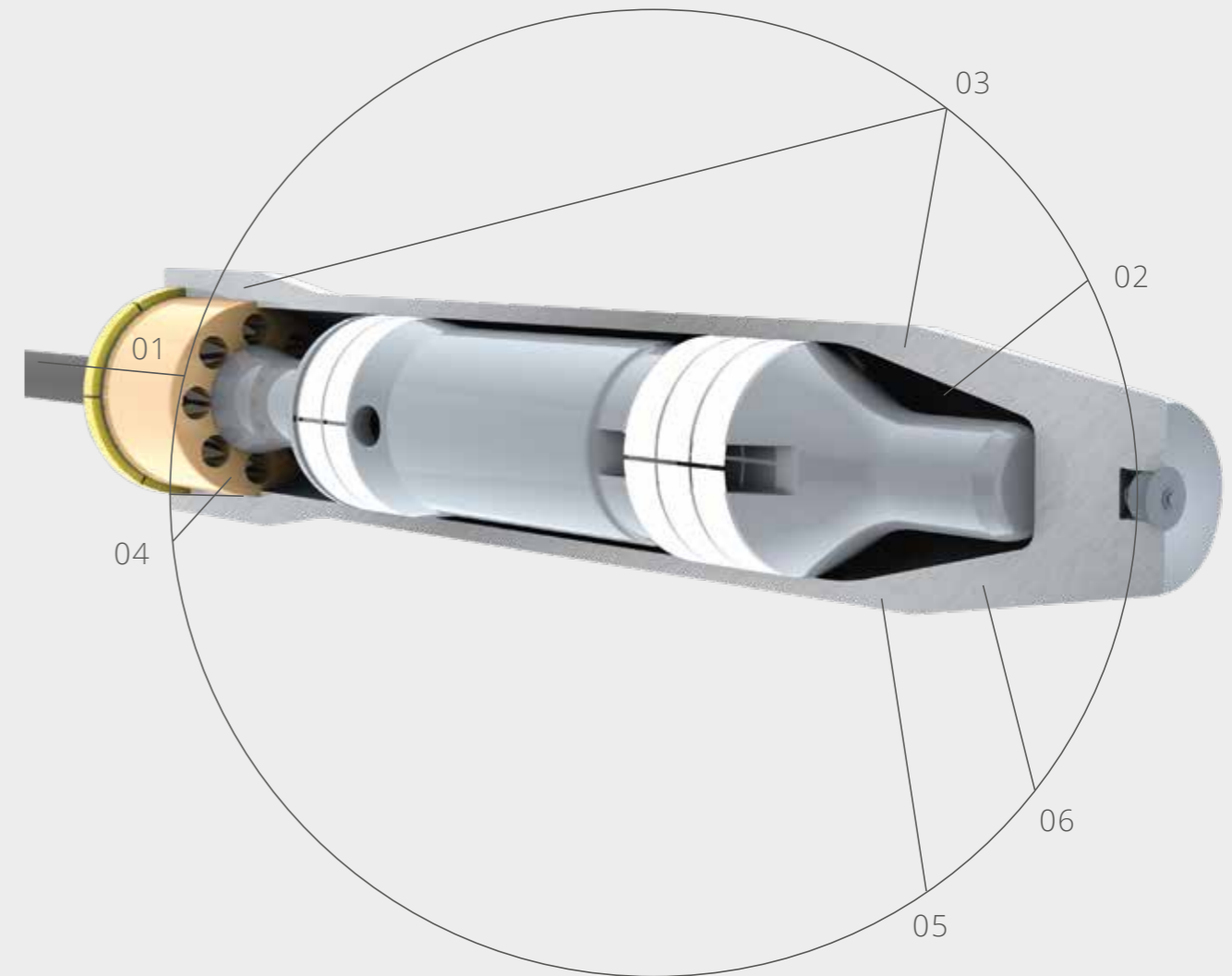

FULL POWER AHEAD

The massive piston is bedded on several slider belts which prevent the material-wearing friction of metal on metal. Sealing rings minimise air consumption and increase performance, thus leading to greater efficiency - the rate of advance is raised accordingly.

- 01 **Simple operation**
compressed air on/off, no additional control
 - 02 **Housing is chromium-plated inside**
for long lasting maximum efficiency
 - 03 **Front and rear cone**
 - 04 **Elastically mounted control**
minimal wear despite the application of extreme loads
 - 05 **Solid housing in one part**
heavy-duty without seams or screwed fittings
 - 06 **Greatest ramming impact**
for high rate of progression
- Short versions for special applications**
and operation within confined spaces
- Versatile accessories available**

DYNAMIC PRODUCTIVITY GRUNDOCRACK

REVERSE GEAR / SERVO CONTROL



With the easy to handle servo control, you switch over from forward into reverse gear by simply throwing the lever.

FORGED FROM ONE PIECE



The massive housing consists of only one piece, manufactured from a single forged part and then galvanised. Due to precise deep hole boring, the piston impact makes its way to the head of the machine, effectuating direct force transmission.



Pulling chain / Pressure hose

PE pipe connection

Front expander

Pulling rope

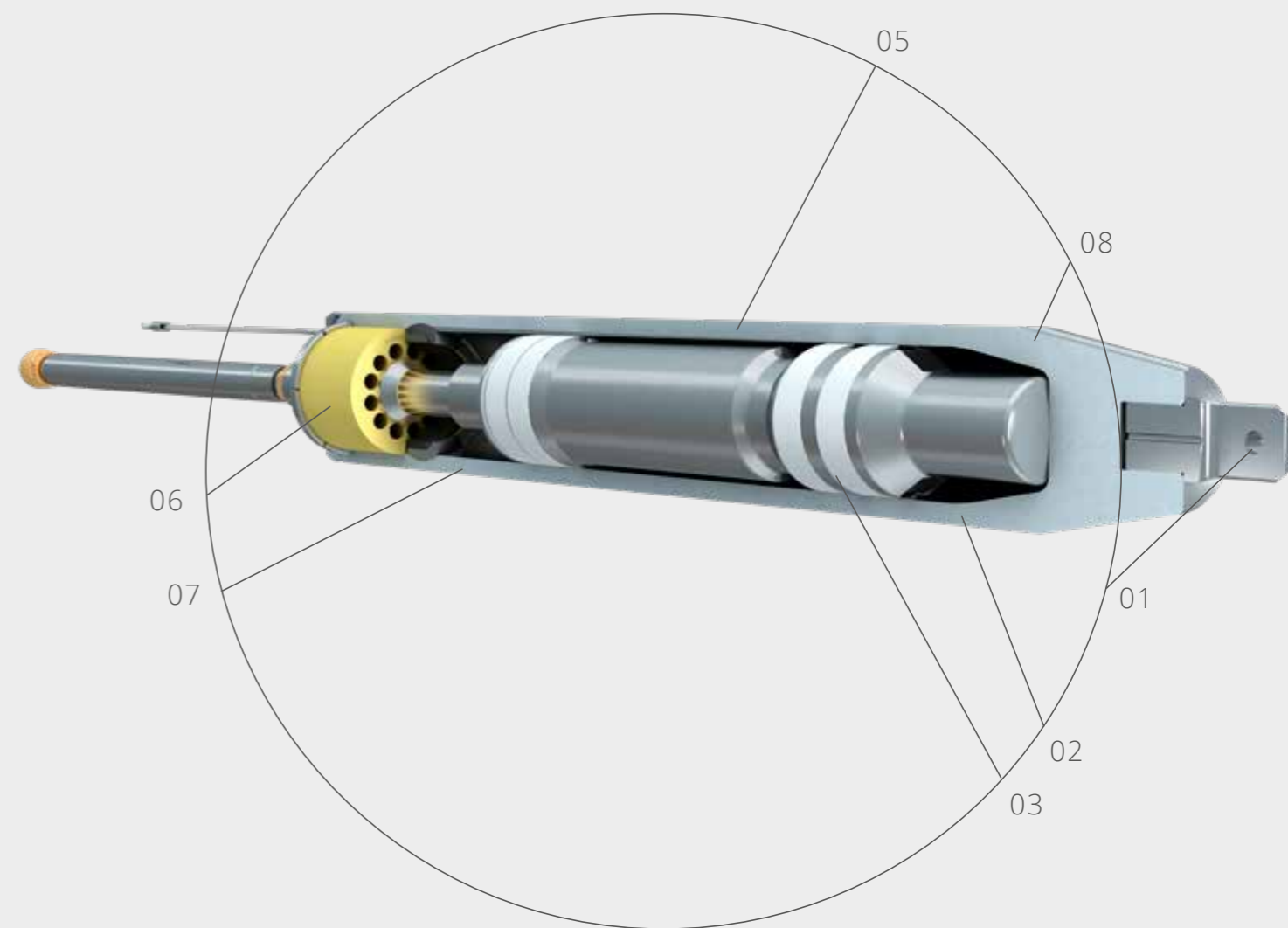

- 01 **Pulling eye for cable connection**
guiding of the machine right on target
- 02 **Smooth machine housing**
simple recovery of the machine through the new pipe in limited space
- 03 **High impact energy**
- 04 **Chromium-plated inner and outer housing**
for long lasting maximum efficiency
- 05 **Elastically mounted control**
minimal wear even with extreme load
- 06 **Heavy-duty one-piece housing**
without seams or screwed fittings
- 07 **Front cone**
direct/optimal power transmission into the expander

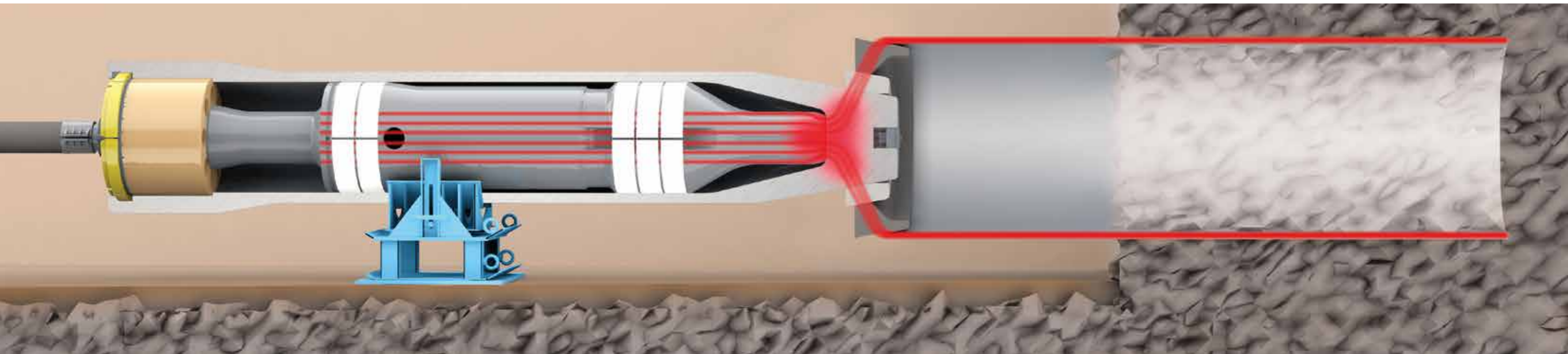

METHOD

DYNAMIC STEEL PIPE INSTALLATION

The piston strikes inside the head of the one-piece ram housing. Passing through the plug-on cone, the generated impact energy is transferred directly to the steel pipe casing which is then driven steadily through the ground.

1. PIPE INSTALLATION

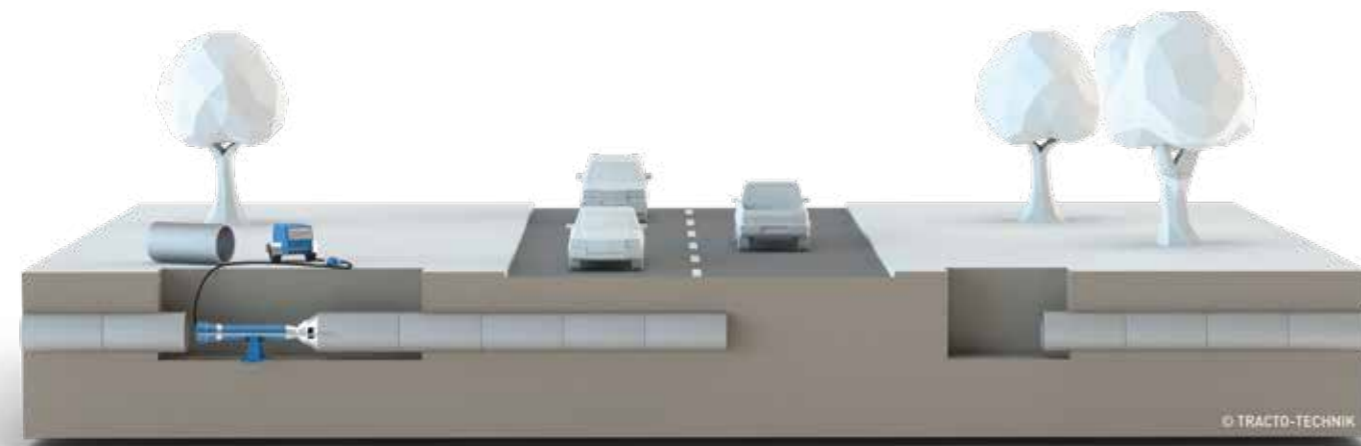

The ramming machine is firmly connected to the pipe to be installed using an attachable cone before it is aligned axially behind the pipe with the aid of the lifting cushion. Thanks to the soil removal adapter or cone, the soil inside the pipe can partially escape while the pipe is being driven forward.

2. SOIL REMOVAL

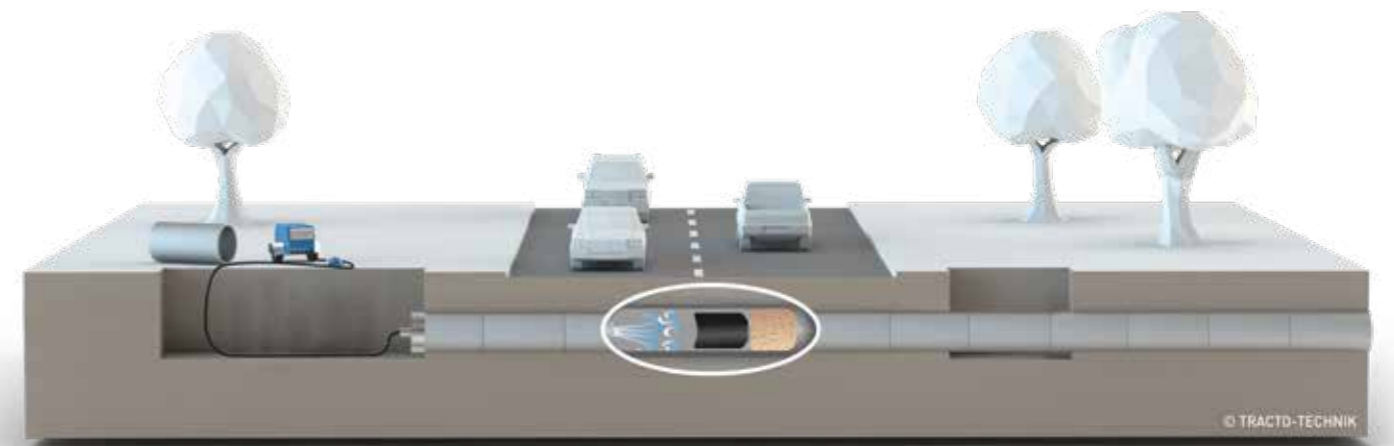

The soil which is gathered inside open pipe during the ramming process, is finally expelled into the target pit using compressed air and/or water. Alternatively, the soil can be drilled out, flushed out or, dredged out if necessary.

APPLICATIONS

DYNAMIC STEEL PIPE INSTALLATION

UNDERCROSSINGS

Pneumatically driven GRUNDORAM horizontal rammers are used for the dynamic installation of steel pipes up to Ø 4,000 mm underneath roads, railway tracks, buildings and rivers over lengths up to 80 m.

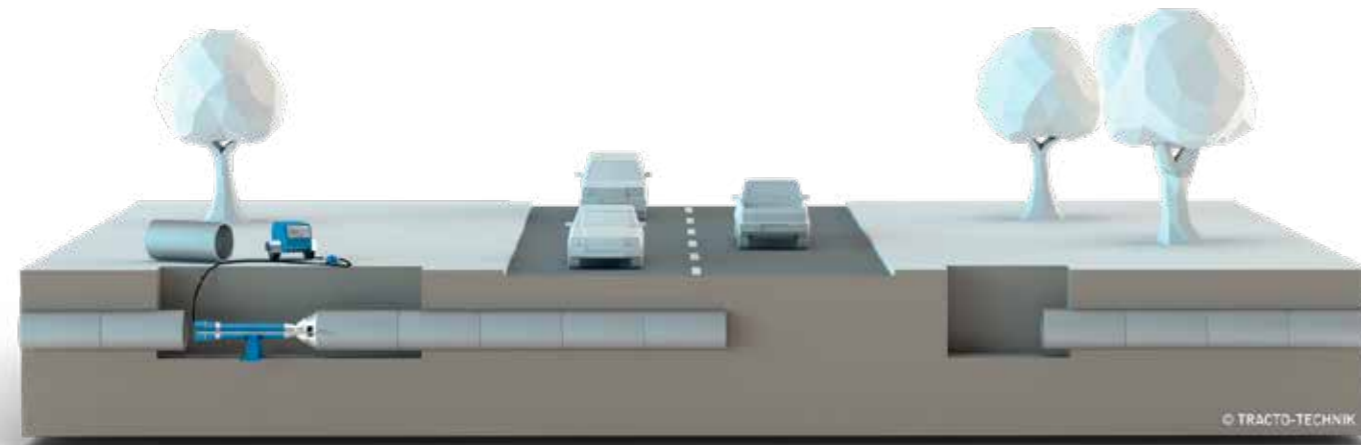

HDD-ASSIST

The rammers are also perfectly suitable for supporting HDD operations (HDD Assist & Rescue).

- **CONDUCTOR BARREL**
In soils which are impossible to bore through, a steel pipe is rammed through the relevant soil layer the fluid-assisted horizontal drilling operation can then commence.
- **PULL-BACK ASSIST**
When pulling in steel pipes for HDD, the GRUNDORAM can give dynamic support or release pipes if they become jammed. The ramming machine is firmly connected to the steel pipe at the rear, guaranteeing efficient impact energy transmission.
- **HDD ROD RECOVERY**
Pulling out trapped drill rods with the aid of an adapter and dynamic ramming force
- **BORE SALVAGE**
Retrieving jammed product casing pipes after the HDD operation



VERTICAL APPLICATIONS

When applied vertically, the pipe ramming technique can be used for a number of different applications.

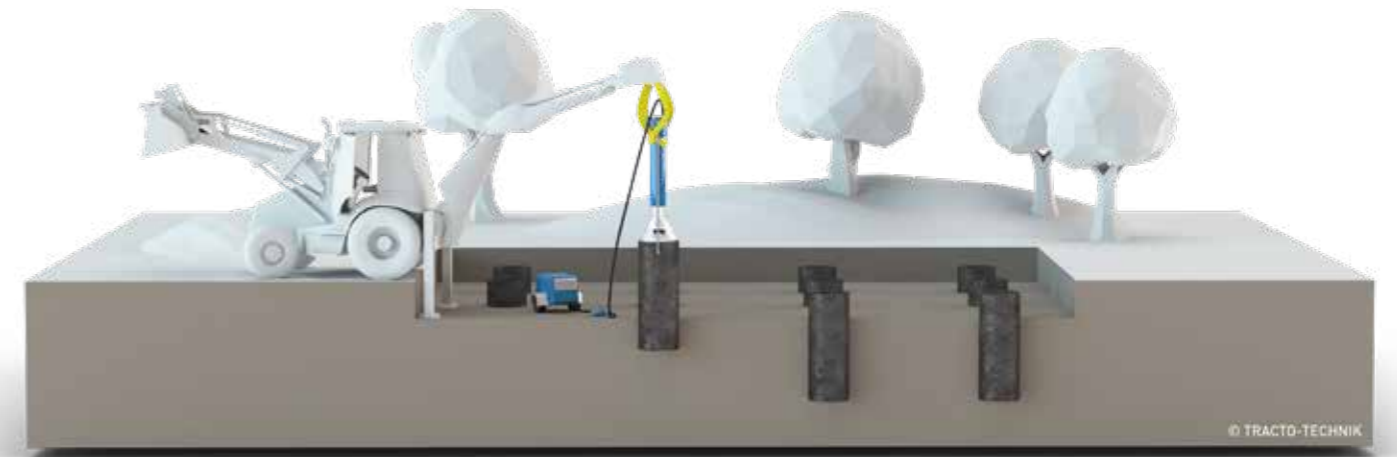

- **FOUNDATIONS AND PILE FOUNDATIONS**
For overhead signs, noise barriers, building securities etc.
- **WELL CONSTRUCTION**
Vertical steel pipe driving for installing a well. Emptying with round grabs
- **RAMMING IN SHEETING WALLS**
Steel sheet piles or double T-beams, for securing construction pits etc.

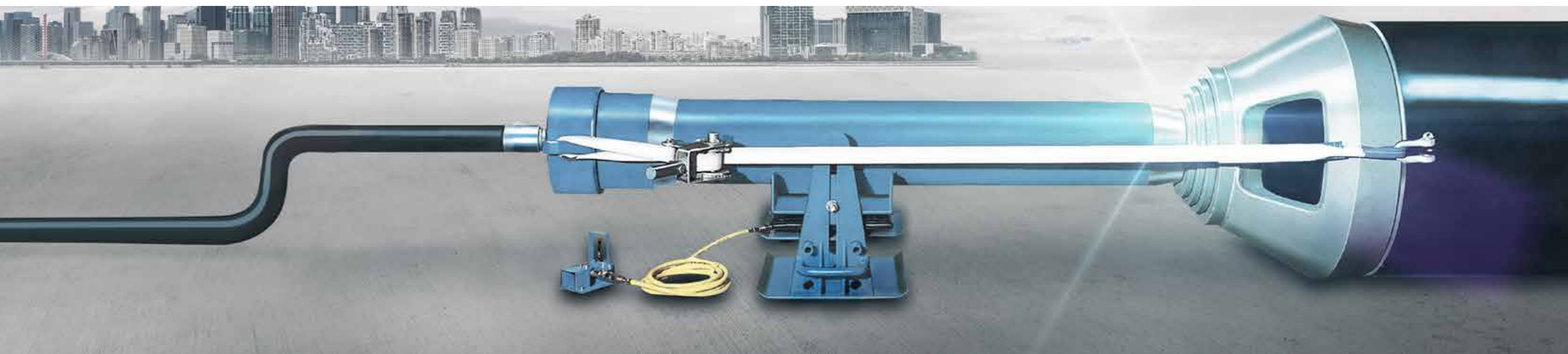

WELL-EQUIPPED ACCESSORIES FOR DYNAMIC STEEL PIPE INSTALLATION

Accessories that are perfectly adapted to the ramming machine guarantee optimum progress in every type of soil. Robustness and durability of all parts are guaranteed.



PLUG-ON CONES

Using attachable taper-lock ram cones, the GRUNDO-RAM is firmly connected to the pipe that is to be installed.



IMPACT SEGMENTS

The multi-part impact segments prevent pipe end flare and improves the optimal induction of impact power.

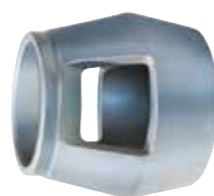

SOIL REMOVAL ADAPTER

With a soil removal adapter or taper-lock ram cones, the soil inside the pipe can partially escape while the pipe is being driven forward.



CUTTING SHOE

Cutting shoes reinforce the cross section of the front-end pipe, protect the insulation of the pipe and reduce coat friction both inside and out.

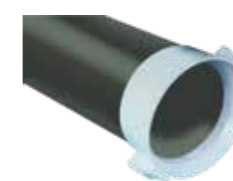

LUBRICATING CUTTING SHOES

Lubricating cutting shoes additionally lubricate the pipe, inside and outside, thus reducing friction and facilitating the pipe drive.



THE 7-L OIL LUBRICATOR

Is built in between the compressor and the machine to enable lubrication of the internal piston.



PRESSURE PLATE WITH RIGID FOAM PIG

The pressure plate closes the end of the pipe, making it pressure resistant to enable pushing the soil core out. Depending on the type of soil, a pig may be necessary to seal the front.



STARTING CRADLE WITH LIFTING CUSHION

With the lifting cushion positioned inside the starting cradle, the heavy ramming machines can be lifted and lowered without effort. Available in 4 types all with adequate lifting force

Further accessories available upon request





METHOD

DYNAMIC PIPE BURSTING

The air-driven pipe cracking machine shatters the old pipe while advancing through the old pipe and radially displaces the fragments into the surrounding soil. The bore hole for the new pipe is extended at the same time. The pulling force of a winch supports the pipe cracker, guaranteeing safe guidance through the given pipe path.



FRONT EXPANDER (GRUNDOCRACK)



GRUNDOCRACK with smooth front expander and PE connection piece for long pipes

REAR EXPANDER (GRUNDORAM)



GRUNDORAM with smooth rear expander and PE connection piece for long pipes

APPLICATIONS

DYNAMIC PIPE RENEWAL

DYNAMIC PIPE BURSTING (LONG PIPE)

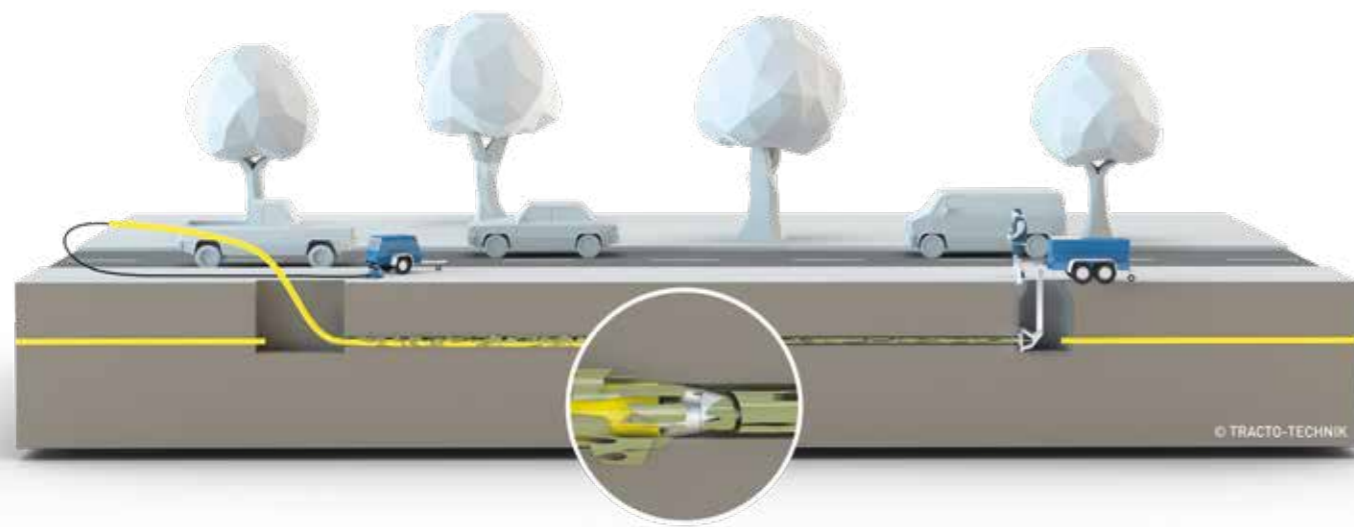

DYNAMIC PIPE BURSTING (SHORT PIPES)

Trenchless renewal in the existing pipe path. Installation of the new pipes with identical or larger nominal diameters.

CALIBRE PIPE BURSTING (LONG PIPES)

Partial damage is expanded dynamically and a new pipe is pulled in simultaneously.

TIGHT-IN-PIPE (TIP)

Short or long pipe relining of concrete or stoneware pipes. The new pipe fits tightly inside the old pipe.





WELL-EQUIPPED ACCESSORIES FOR DYNAMIC PIPE RENEWAL

We offer a wide range of precisely fitting accessories for adaption to different soil conditions and old pipe materials during pipe renewal.



SMOOTH EXPANDER



EXPANDER WITH CUTTING BLADES



SHORT PIPE TENSIONING DEVICE
Spannfix with pulling rope



THE 7-L OIL LUBRICATOR
is built in between the compressor and the machine to enable lubrication of the internal piston.

GRUNDORAM STANDARD MACHINES

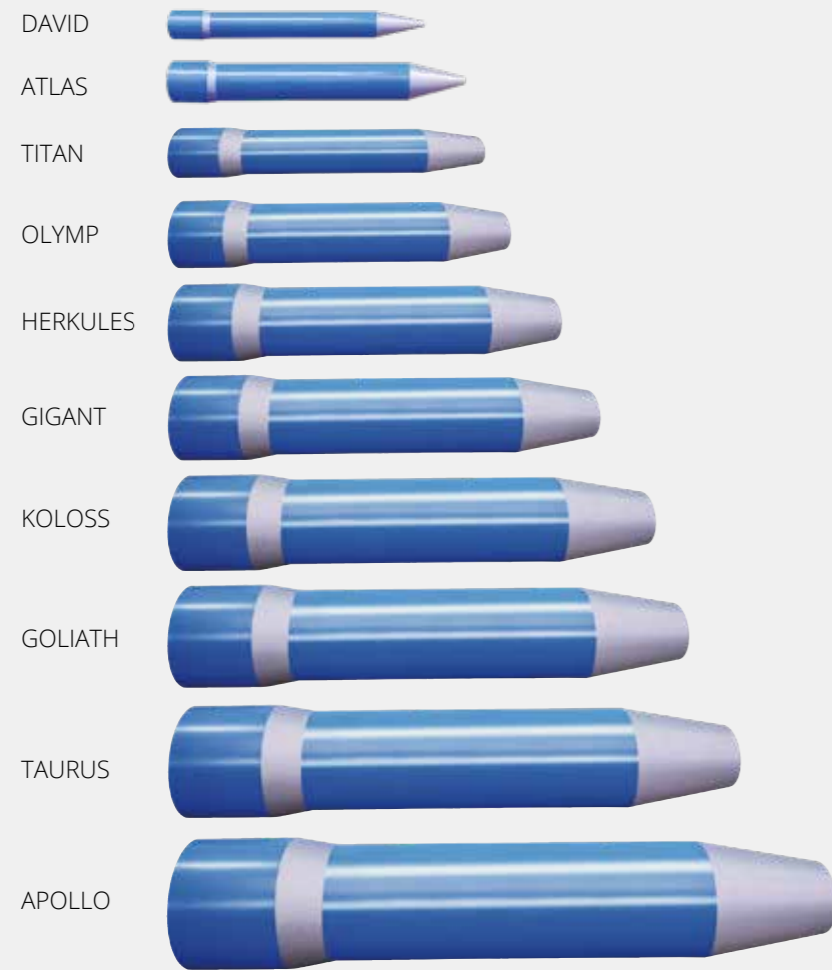

GRUNDORAM MINI MACHINES



- No abutment required - short set-up times
- One-piece, deep-hole drilled housing - high creep rupture strength and optimum energy transmission with maximum impact force and enormous thrust power
- Segmental machine lock with elastically suspended control - safe, positive locking design
- Service-friendly design with only one-sided machine closure
- Mini machines with shortened overall length for use in confined spaces and with reverse gear for simple and ergonomic disassembly of the ramming accessories

GRUNDORAM TYPE	MINI ATLAS		MINI OLYMP		MINI GIGANT	
	METRIC	IMPERIAL	METRIC	IMPERIAL	METRIC	IMPERIAL
Machine Ø (mm / in)	125	4.9	180	7.1	270	10.6
Rear cone Ø (mm / in)	140	5.5	230	9.1	330	13.0
Length (mm / in)	946	37.2	1.080	42.5	1.230	48.4
Installation pipe in pipe (mm / in)	250	9.4	450	17.7	450	17.7
Weight (kg / lbs)	60	132.3	175	385.8	460	1,014.1
Air consumption (m ³ /min / cfm)	1,7	60	3,5	124	10,0	353
No. of strokes (min ⁻¹)	580	580	500	500	430	430
Impact power (Nm / joule)	180	180	720	720	2.000	2,000
From pipe ND on	50	2.0	100	3.9	200	7.9

GRUNDORAM-TYP	DAVID		ATLAS		TITAN		OLYMP		HERKULES		GIGANT		KOLOSS		GOLIATH		TAURUS		APOLLO	
	METRIC	IMPERIAL	METRIC	IMPERIAL	METRIC	IMPERIAL	METRIC	IMPERIAL	METRIC	IMPERIAL	METRIC	IMPERIAL	METRIC	IMPERIAL	METRIC	IMPERIAL	METRIC	IMPERIAL	METRIC	IMPERIAL
Machine Ø (mm / in)	95	3.7	130	5.1	145	5.7	180	7.1	216	8.5	270	10.6	350	13.8	460	18.1	600	23.6	800	31.5
Rear cone Ø (mm / in)	112	4.4	145	5.7	160	6.3	195	7.7	235	9.3	300	11.8	400	15.7	510	20.1	670	26.4	900	35.4
Length (mm / in)	1.490	58.7	1.453	57.2	1.545	60.8	1.690	66.5	1.913	75.3	2.010	79.1	2.341	92.2	2.852	112.3	3.645	143.5	4.400	173.2
Weight (kg / lbs)	59	130.1	95	209.4	137	302	230	507.1	368	811.3	615	1,355.8	1.180	2,601.5	2.465	5,434.4	4.800	10,582.2	11.500	25,353.1
Air consumption (m ³ /mi / cfm)	1,2	42	2,7	95	4,0	141	4,5	159	6,5	230	12,0	424	20,0	706	35,0	1,236	50,0	1,766	100	3,531
No. of strokes (min ⁻¹)	345	345	320	320	310	310	280	280	340	340	310	310	220	220	180	180	180	180	180	180
Impact power (Nm / joule)	230	230	420	420	800	800	890	890	1.440	1,440	2.860	2,860	6.820	6,820	11.600	11,600	18.600	18,600	40.500	40,500
From pipe ND on (mm / in)	50	2	50	2	100	3.9	100	3.9	120	4.7	200	7.9	280	11	380	15	380	15	600	23.6

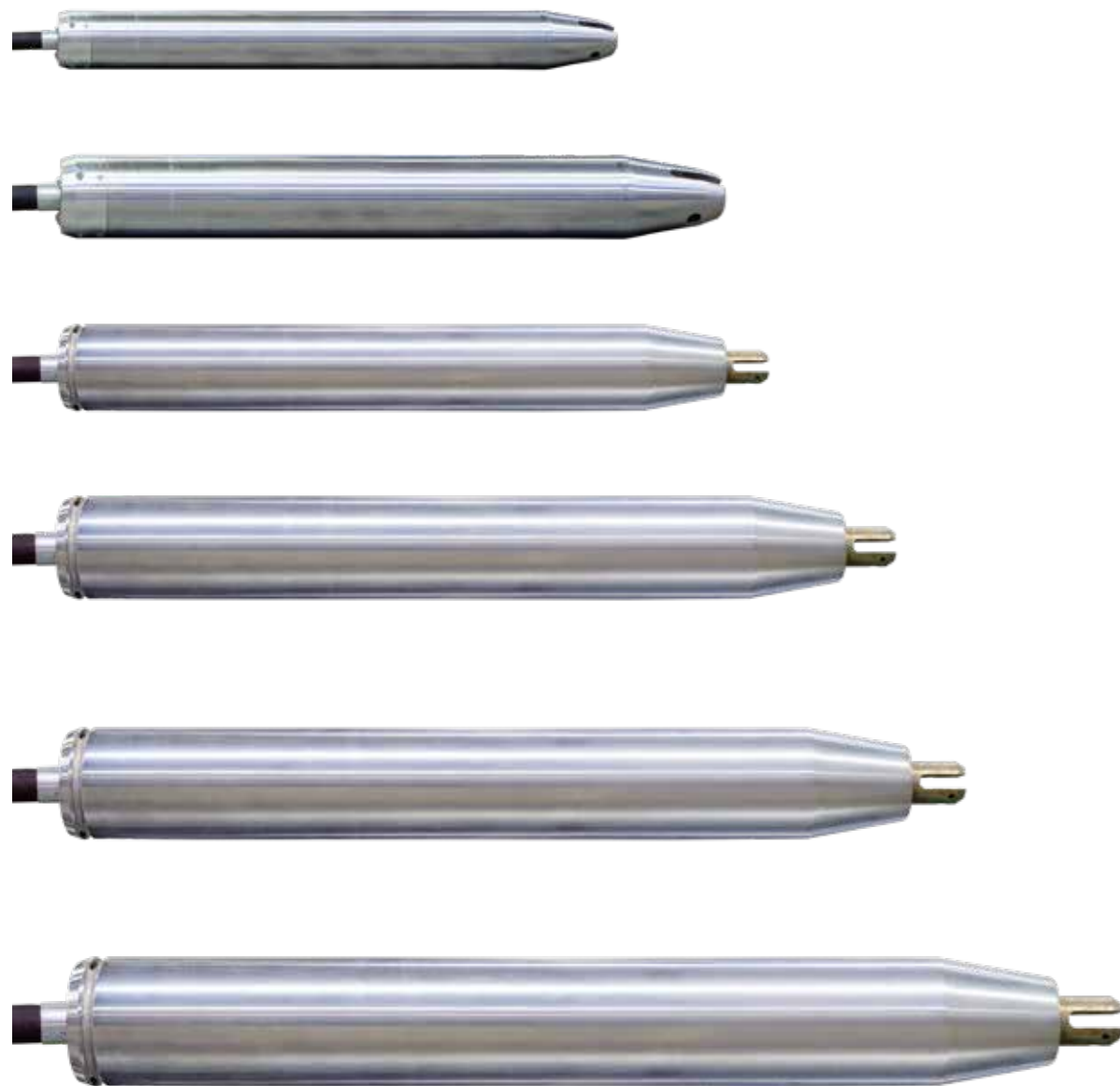

TECHNICAL SPECIFICATIONS

GRUNDOCRACK

- Massive one-piece housing - heavy-duty without welded or screwed connections
- Smooth machine body - easy recovery through the new pipe in confined spaces
- Reverse gear with servo control - easy loosening of accessories and ergonomic handling
- Pulling eye for rope connection - on-target guidance of the machine
- Front cone - direct/optimal force introduction into the expander
- Elastically mounted control - gentle on materials

GRUNDOCRACK	PCG 130		PCG 180		PCG 200		PCG 260		PCG 350	
	METRIC	IMPERIAL	METRIC	IMPERIAL	METRIC	IMPERIAL	METRIC	IMPERIAL	METRIC	IMPERIAL
Machine Ø (mm / in)	130	5.1	180	7.1	208	8.2	280	11.0	380	15.0
Length (mm / in)	1.460	57.5	1.700	66.9	2.100	82.7	2.290	90.2	2.730	107.5
Weight (kg / lbs)	95	209.4	230	507.1	395	870.8	615	1,355.8	1.180	2,601.5
Upsizing Ø (mm / in)	280	11.0	392	15.4	450	17.7	560	22.0	630	24.8
New pipe OD (mm / in)	225	8.9	315	12.4	355	14.0	450	17.7	560	22.0
No. of strokes (min ⁻¹)	320	320	280	280	290	290	310	310	220	220
Air consumption (m ³ /min / cfm)	2,7	95	4,5	159	6,5	230	12	424	20	706
with blade head		x		x		-		-		-
with pulling eye		-		x		x		x		x



SERVICES ALL AROUND TRENCHLESS TECHNOLOGY INTELLIGENT SOLUTIONS WITH ADDED VALUE

Be it before the purchase or after, in person or online – we are always at hand with help and advice for you. We offer you comprehensive services and consultation that are specially tailored to the requirements in trenchless pipeline construction. Our services are as diverse as our range of products so you can concentrate fully on your business.

www.TRACTO-TECHNIK.com/Services

DIGITAL SOLUTIONS

On our website, you can find all of the main information about our company, our products and their use in digital form. You can view the contents that interest you quickly and easily via the user-friendly, clearly structured navigation. Links to our social media channels can also be found there. For ordering accessories and spare parts for our NODIG technology there is our **eShop**. You can order merchandising items with the 'mole label' there as well.

Our cloud-based solutions for the HDD drilling technology combine planning, execution, billing, documentation and service in a central way. With the **Cockpit**, you always have all key machine data in view irrespective of place and time. With the **QuickPath**, you can plan the shortest and safest bore path in next to no time. That way, you can apply the analogue machine technology even more efficiently and profitably, simply via PC, smartphone or tablet.

FINANCING & WARRANTY

We offer attractive financing solutions for new and used machines to our customers and sales partners through TRACTO-TECHNIK Finance GmbH. Be it financing, hire purchase, various types of leasing or insurance: we provide extensive expert advice in order to find the tailored solution for you. Discretion goes without saying.

USED EQUIPMENT

Your used equipment is in good hands with us. Be it our own or third-party products, be it with new purchase or not – you can rely completely on our full service. We assess the equipment on-site, advise you on purchase or trade-in and carry out the professional repair. With the "Certified Used Equipment" seal of approval, we achieve the best price for you via our use machine website with access to one of the world's largest construction machinery platforms.

AFTER SALES

Via our worldwide service network, we are always there for you, even after the purchase. Alongside the headquarters in Lennestadt, a total of seven TRACTO-TECHNIK customer centres in Germany as well as our worldwide sister companies and sales partners guarantee fast supply of spare parts and immediate availability. Our competent service staff offer fast assistance to make sure that you do not lose any valuable in case of emergency – wherever you may be.

TRAININGS

Qualified trainings in theory and practice are a central concern for us to enable users and partners to achieve the greatest possible success with our products. The broad course range does not only address users, machine operators and service technicians but equally specialists and managers as well as planners and contractors who would like to learn more about the versatile applications of the various NODIG systems. Our tailor-made trainings are held at our company locations or individually at your end by certified trainers. Contents, dates and registration on our website.

GEOSERVICE

In Germany, our Geoservice provides far-reaching geological expertise to support your projects. We offer advice on planning and drilling, for example in the courses of planned bore paths or by submitting queries about building ground. Furthermore, we write geological assessments, review construction documents to determine the potential for supplements and draw up corresponding statements.

WORLDWIDE

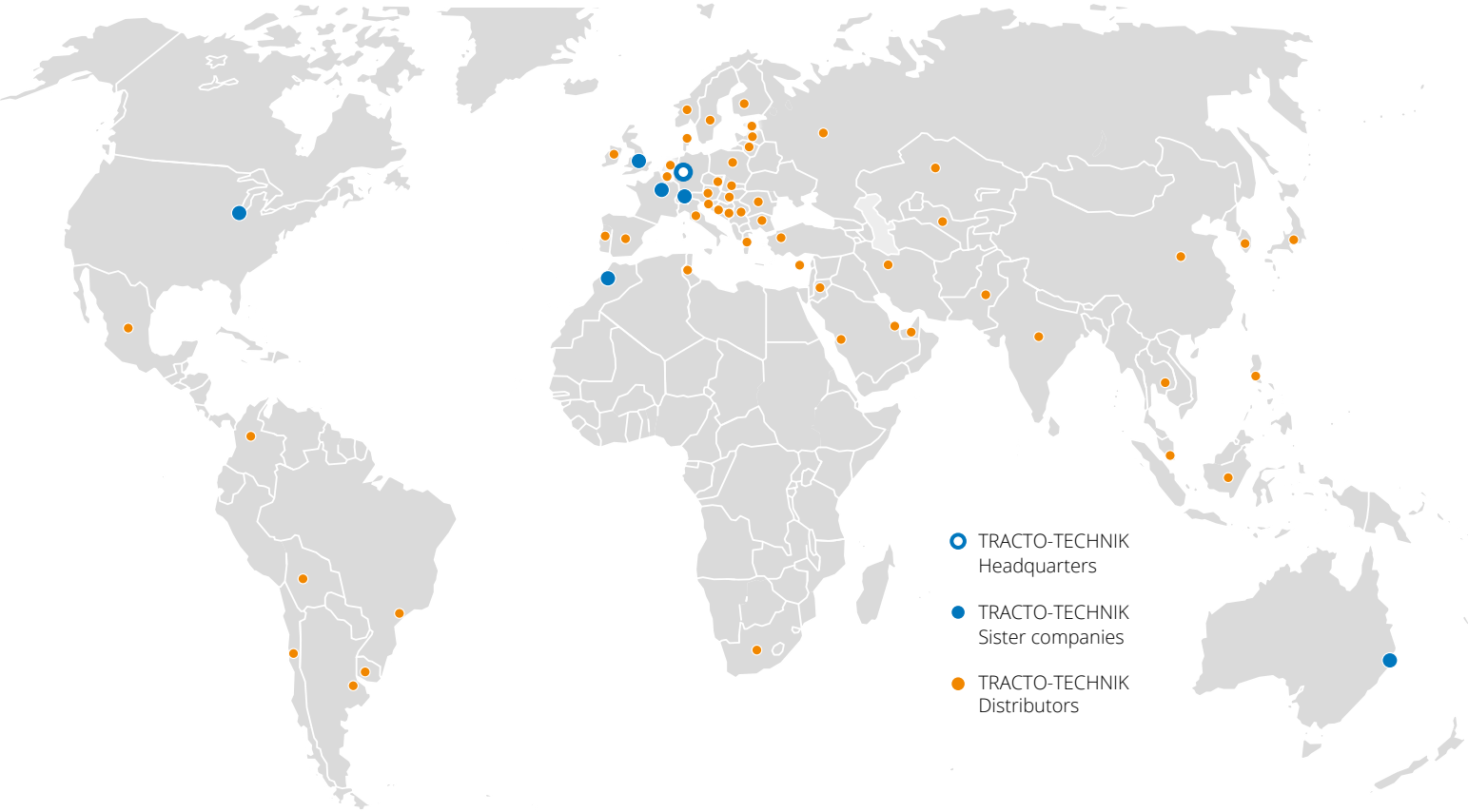

- TRACTO-TECHNIK Headquarters
- TRACTO-TECHNIK Sister companies
- TRACTO-TECHNIK Distributors

Germany
TRACTO-TECHNIK GmbH & Co. KG
Headquarters
 Paul-Schmidt-Straße 2
 57368 Lennestadt
 Tel. +49 2723 808-0 Fax -180
 info@TRACTO-TECHNIK.com
 www.TRACTO-TECHNIK.com

Switzerland
TRACTO-TECHNIK Schweiz AG
 Ratihard 3
 8253 Diessenhofen
 Tel +41 79 820 38 97
 info@TRACTO-TECHNIK.ch
 www.TRACTO-TECHNIK.ch

USA
TT TECHNOLOGIES Inc.
 2020 East New York Street
 Aurora, IL 60502
 Tel +1 630 851 8200
 Fax +1 630 851 8299
 info@TTTECHNOLOGIES.com
 www.TTTECHNOLOGIES.com

United Kingdom
TRACTO-TECHNIK UK Ltd
 10 Windsor Road
 Bedford MK 42 9SU
 Tel +44 1234 342566
 Fax +44 1234 352184
 info@TRACTO-TECHNIK.co.uk
 www.TRACTO-TECHNIK.co.uk

Australia
TRACTO-TECHNIK Australia Pty Ltd.
 6 Devlan Street
 Mansfield, Qld 4122
 Tel +61 7 3420 5455
 Fax +61 7 3420 5855
 info@TRACTO-TECHNIK.com.au
 www.TRACTO-TECHNIK.com.au

France
TRACTO-TECHNIK France S.a.r.l.
 1/3 Rue de la Prairie
 F-77700 Bailly Romainvilliers
 Tél +33 1 60 42 49 40
 Fax +33 1 60 42 49 43
 info@TRACTO-TECHNIK.fr
 www.TRACTO-TECHNIK.fr

Morocco
TRACTO-TECHNIK Afrique S.a.r.l.
 Route de Tamesna 4022
 Poste 2044, 12220 Tamesna
 Tel +212 5 37 40 13 63 / 64
 Fax +212 5 37 40 13 65
 info@TRACTO-TECHNIK.ma
 www.TRACTO-TECHNIK.ma

Presented by your TRACTO-TECHNIK partner:



OCTOPUS
 ELECTRONICS
 6 Ingwe Road, Sebenza, 1609
 +27 (0) 11 524 0144
 info@octopuse.co.za
www.octopuse.co.za



trenchless technology – simple & easy